

## RESEARCH TITLE

# DESIGN, FABRICATION AND PERFORMANCE EVALUATION OF WHEAT CROP THRESHER FOR SMALL-SCALE FARMERS

Fahad Awad Hassan Alwagie<sup>1</sup>

<sup>1</sup> Specialist of Agricultural Engineering, Ministry of Production and Economic Resources, Dongola, Northern state, Sudan.

Email: fahadalwagie@gmail.com

:

HNSJ, 2024, 5(1); <https://doi.org/10.53796/hnsj51/15>

Published at 01/01/2024

Accepted at 14/12/2023

## Abstract

Wheat crop thresher had been designed, manufactured and tested in the workshop of the department of agricultural engineering, faculty of agricultural sciences, university of Dongola, northern state of Sudan under collaboration of Alshamaliya for Agricultural Services Company, for small-scale farmers were made simple and includes threshing cylinder, concave, shaker, pulleys and sieve. For purpose of improving thresh efficiency the cylinder-concave clearance was made adjustable at two points.

The thresher was tested for wheat variety (Imam) at two levels of concave-clearance (15, 20 mm), two fan speeds (1042, 1390 rpm), two cylinder speeds (650, 900 rpm) and two cylinder types using (rasp-bar type, wire-loop type) three replications in a randomized complete block design. Results obtained showed a high efficiency of threshing at clearance 20 mm in fan speed of 1390 rpm at a cylinder speed of 900 rpm and rasp-bar type cylinder.

The shape and diameter of concave and sieve holes which designated according to the geometric mean diameter for tested wheat has given a very good results based on threshing efficiency (TE), separation losses (SL), cleaning efficiency (CE) and product purity (Pp) which were 69.9 %, 30.1 %, 82.3 % and 93.2 % respectively.

**Key Words:** Wheat crop thresher, Small-scale farmers, Geometric mean diameter.

## 1. Introduction:

Wheat in the Sudan is predominantly produced in the irrigated production system and has been targeted as a major food security crop in the Sudan since the 1980s (El Faki, 2000). The average area allocated for wheat represented only 3% of total area under cereals but still accounting for about 11.7% of total cereal production during the period from 2006-2009 (MoFEP, 2012). Other cereals (mainly sorghum and millet) are produced in the rain fed system. Most known areas for wheat production include Gezira and New Halfa schemes, Northern, River Nile and White Nile states.

Generally, the average wheat yields in Sudan are very low and uncertain (Saad, 2010). The major reasons for low productivity and instability in addition to heat stress also includes late planting of wheat, non-availability of improved inputs like seed, inefficient fertilizer use, weed infestation, shortage of irrigation water and delayed harvesting. Moreover, farmers are not aware of modern technologies because of weak extension services system (Kabesh *et al.*, 2009).

Wheat harvesting in Northern State is the most tedious and the most costly agricultural operation. It costs about 20 % of the total variable cost of agricultural production next to irrigation cost (31.5 %), (Fageeri, 2005). Farmers manually cut the crop using sickles, tie it into bundles and collect it on a heap, which is later threshed using stationary thresher.

Many types of processing equipment have been developed and used in many parts of the world for grain threshing; however, most of these machines are expensive and require high power to operate, which are therefore beyond the reach of majority of small scale farmers. Hence, there is need to design, fabricate and evaluate wheat crop thresher which is portable, low cost and can operate with electric motor or diesel engine in rural areas.

## 2. Literature reviews:

Proper design of machines and processes to harvest, handle and store agricultural materials and to convert these materials into food and feed requires an understanding of their physical properties. Strivastava *et al.*, (1990) noted that the grain separation is very sensitive to variation in the physical properties of grain, straw and chaff.

Many researchers have investigated that fan speed, cylinder speed and concave clearance are the key machine parameters that can influence the threshing efficiency of a mechanical thresher (Singh *et al.*, 1981; Joshi *et al.*, 1981; Ghaly, 1985; Behera *et al.*, 1990).

Ponican *et al.*, (2009) investigated threshing mechanism parameters of maize crop. They concluded that peripheral speed and clearance between cylinder and concaves were the most important factors affecting the crop quality.

Sarwar and Khan (1987) compared the performance of rasp-bar and wire-loop cylinders for threshing rice crop. They reported that the rasp-bar gave higher percentage of husked grain than wire-loop for all levels of evaluated peripheral speeds. Addo *et al.*, (2004) reported that the rasp-bar drum type provides more surface area for frictional impact.

Arnold (1964) reported that increasing concave length increased concave separation. The effect of concave length when threshing wheat and barley was studied by Cooper (1978). He reported that a 25% increase of arc from 84° to 105° increased grain separation by 17%.

Singh and Kumar (1976) reported that increasing the cylinder speed decreases un-threshed seed. Dash and Das (1989) stated during development of power operated paddy thresher that, paddy crop with high cylinder peripheral velocity in order to minimize the total un-threshed loss. Abo El-Khair (1991) concluded that the un-threshed seed losses decreased with an increase in drum speed. El-Haddad (2004) designed and manufactured chopping, threshing and winnowing machine suitable for the requirements of some crops residues recirculation. The experimental results showed that the un-threshed grain losses was decreased as the cylinder speed was increased.

According to Kolganov (1956) the higher cylinder speeds cause damage to the seeds. Vas and Harison (1969), noted that the cylinder speed was an influencing factor as far as grain damage in

wheat was concerned. Singh and Kumar (1976) reported that increasing the cylinder speed increases grain damage. Kumar and Goss (1979) used data obtained from 224 field experiments to present models for combine performance. Model presented for broken seeds indicated significant correlation between cylinder speed and seed breakage. They found that an increase from 6 to 9% in broken seeds could be observed by an increase in cylinder speed from 20 to 25 m sec<sup>-1</sup>. Joshi and Singh (1980) developed Pantnagar IRRI multi-crop thresher. They observed that increase in cylinder speed reduces the cylinder loss at the cost of increase in visible damage for all the cylinder concave clearance. Sharma and Devnani (1980) at higher speeds, the visible grain damage was 5%. Singh *et al.* (1981) investigated the effect of crop and machine parameters on threshing effectiveness and seed quality of soybean. They determined the external damage inflicted on the grain by finding the weight of broken grains in specified samples. They found that external damage increased with increase in cylinder speed. Anwar and Gopta (1990) reported that the percentage of grain damage increased with an increase in drum speed for all feed rates and concave combinations. Alonge and Adegbulugbe (2000) stated that kernel damage increases as the speed of the machine increases. Sudajan *et al.*, (2002) reported that visible grain damage increased with increasing drum speed. Johnson (2003) proposed that a thresher should be operated at the lowest cylinder speed that will shed the most grain with acceptable levels of damage to grain. The effect of drum speed was investigated on percentage of damaged grains and threshed pods in a finger type thresher for chickpea (Khazaei *et al.*, 2003). Results indicated that the drum speed had the highest effects on the intensity of damage. El-Haddad (2004) designed and manufactured chopping, threshing and winnowing machine suitable for the requirements of some crops residues recirculation. The experimental results showed that the visible grain damage increased as the cylinder speed increased. Vejasit and Salokhe (2004) studied machine-crop parameters of an axial flow thresher for soybean and reported that threshing drum speed significantly affected the grain damage during soybean threshing. Askari Asli-Ardeh *et al.*, (2008) during the test of a power tiller operated small thresher concluded that grain damage increased with increasing peripheral speed. Chimchana *et al.*, (2008) developed an unequal speed co-axial split-rotor thresher for rice. Results of their study indicated that optimum speed for threshing rotor was considered to be 600 rpm and by increasing this speed above 800 rpm the grain damage was increased. Ponican *et al.*, (2009) investigated threshing mechanism parameters of maize crop. Their experiment results with the tangential threshing mechanism showed that with increasing the cylinder peripheral speed from 9.4 to 21.4 m s<sup>-1</sup>, the grain damage increased from 3.8 to 6.01%.

The studies made by Singh and Kumar (1976) showed that increasing cylinder tip speed increases threshing efficiency. Ige (1978) studied the threshing and separation performance of a locally built cowpea thresher. The results showed that the speed of drum affected the threshing efficiency of cowpea. Sharma and Devnani (1980) reported that threshing efficiency increased with the increase of cylinder speed. Desta and Mishra (1990) developed and conducted performance evaluation of a sorghum thresher. Their results showed that threshing efficiency increased with an increase in cylinder speed for all feed rate and cylinder concave clearances. Hadad (2000) stated that the threshing efficiency increased with increasing drum speed and decreasing feed rate. Simonyan and Oni (2001) reported that the threshing effectiveness was also found to be affected by the cylinder speed. El-Haddad (2004) designed and manufactured chopping, threshing and winnowing machine suitable for the requirements of some crops residues recirculation. The experimental results showed that the threshing efficiency increased as the cylinder speed increased. Vejasit and Salokhe (2004) studied machine-crop parameters of an axial flow thresher for soybean and reported that threshing drum speed significantly affected the threshing efficiency during soybean threshing. According to Adewumi *et al.*, (2007) the results of the performance analysis showed that threshing efficiency increased with an increase in cylinder speed and threshing efficiencies was found to be in the range of 54.5% to 100%. Radwan *et al.*, (2009) performed study on the El-Shams type tangential axial flow cereal thresher as developed. It was found that increasing rotor speed tends to increase the threshing efficiency. At air speed (4.8m/s) and moisture content (10.36%), increasing rotor speed from 500 to 700rpm increased the threshing efficiency from 70.2 to 73.7%.

Joshi and Singh (1980) developed Pantnagar IRRI multi-crop thresher. They observed that cleaning efficiency increased with an increase in the cylinder speed of the thresher.

### 3. Materials and methods:

#### 3.1. Determination of geometric mean diameter:

A vernier caliper was used to measure three perpendicular diameters for wheat kernels with 0.05 mm accuracy. In the case of seeds and grains, length, width, and thickness are often used, respectively, to designate the maximum, average, and minimum diameters (Edison and Brogan, 1972). From these axial dimensions,  $D_p$  for the seeds were determined as the geometric mean of the three dimensions given as (Mohsenin, 1970).

$$D_p = (abc)^{\frac{1}{3}} \dots\dots\dots(1)$$

Where: a = length, b = width and c = thickness

#### 3.2 Determination of the kernels mass:

A digital (electronic) scale was used to measure kernel weights for mass with 0.05 g accuracy. The average maximum, and minimum weight for each wheat kernels were determined.

#### 3.3. Physical properties of tested wheat:

Hundred samples of randomly selected wheat kernels of a local Sudanese variety Imam, were measured for length, width, thickness, mass (n=1000 kernels) and geometric mean diameter as given in Table 1;

**Table 1: Physical properties of tested wheat**

Physical properties	min	max	mean
Length l, mm	5.40	7.20	6.26
Width w, mm	2.70	3.50	3.10
Thickness t, mm	2.20	3.40	2.79
1000 kernel mass, g	36.99	38.36	37.57
Geometric mean diameter mm	3.17	4.40	3.78

#### 3.4. Screen characteristics:

Screens are characterized by parameters such as shape of opening, effective size of opening and the coefficient of opening,  $C_o$ .

For circular opening;

$$C_o = \frac{\text{Open Area}}{\text{Total Area}} = \frac{3\pi}{2} \times \frac{D^2}{(D+d)^2} \dots\dots\dots(2)$$

Where;

D = diameter of hole = 2 mm

d = distance between the successive holes = 4.5 mm

For efficient screening,  $C_o$  is taken as 40% (Igbeka, 1984).

Screen size selection for this wheat cleaner is such that the screen retains whole kernels until channeled into the good receptacle, broken kernel and other undersize contaminant passes through it. Screen diameter of 2 mm was chosen.

### 3.5. Machine specifications:

The specification of the wheat crop thresher as at the time of construction is shown in Table 2 below.

**Table 2: Machine Specification**

Component	Description
Overall length	3025mm
Overall width	1500mm
Overall height	1550mm
Machine capacity	75 kg/h
Power requirement	5hp with 1390rpm
Power transmission	V-belts drive with pulley diameters 45mm, 96 or 69.5mm, 285mm and 60 or 45mm
Type of the cylinder	Rasp-bar type cylinder and wire-loop type cylinder with 84 wire-loops
Hole concave sieve (round)	Ø5mm
Fan	Radial fan with 8 blades
Fan blade size	800mm by 130mm
Fan Housing	Ø450mm by 850mm
Airflow channel inlet size	15mm by 850mm
Fan shaft	Ø22mm by 1000mm
Number of sieves (flat)	1; 1200mm by 800mm
hole sieve diameter (round)	Ø2mm
Connecting rod length	300mm
Crank speed	208.5rpm

### 4.6. Experimental design:

The threshing machine was designed and manufactured for threshing wheat crop in Agricultural Engineering Department, Faculty of Agricultural Sciences, University of Dongola, northern state of Sudan under collaboration of Alshamaliya for Agricultural Services Company.

Wheat materials (360 kg variety Imam) was manually collected by hand pulling from the farm of the Dongola Research Station. Each half of the collected material was divided into 48 bundles (7.5 kg each) and each bundle was fed to the locally made machine.

The study operating parameters include:

Two levels of drum speed; DS1= 650 rpm and DS2= 900 rpm.

Two levels of fan speed; FS1= 1042 rpm and FS2= 1390 rpm.

Two levels of concave - drum clearance; C1= 15 mm and C2= 20 mm.

Two types of threshing drum; TD1= rasp-bar drum and TD2= wire-loop drum.

Randomized complete block design was used with sixty treatments replicated three times. For each replication in each treatment the following measurements was made:

Threshed grains by weight (g), Un-threshed grains by weight (g), Grains blown out with chaff by weight (g), Total grains by weight (g), Broken grains by weight (g), Grains with stem by weight (g).

Threshing efficiency (Alizadeh and Bagheri, 2009) is the ratio of total weight of grain threshed to the total weight of grains fed into the threshing, that expressed in percentage. It can be evaluated by equation (3):

$$\text{Threshing efficiency (\%)} = \frac{\text{Weight output}}{\text{Weight input}} \times 100 \% \dots\dots\dots (3)$$

Separation losses (Asli-Ardeh *et al.*, 2009) is the ratio of total weight of un-threshed grain to the total weight of grains fed into the threshing that expressed in percentage. It can be evaluated by equation (4):

$$\text{Separation losses (\%)} = \frac{\text{Un threshed}}{\text{Weight input}} \times 100 \% \dots\dots\dots (4)$$

Cleaning efficiency (Agidi *et al.*, 2013) is the ratio of mass of separated impurities to the total mass of impurities in the millet expressed in percentage and is given as:

$$\text{Cleaning efficiency (\%)} = \frac{\text{mass of separated impurities}}{\text{mass of un-separated impurities}} \times 100 \% \dots\dots\dots (5)$$

Product purity (Igbeka, 1984) this was obtained as the ratio of weight of whole wheat grains in the products to the total weight of products.

This is expressed mathematically as:

$$\text{Product purity (\%)} = \frac{\text{GP}}{\text{GP+BP}} \times 100 \% \dots\dots\dots (6)$$

Where;

GP is the weight of clean wheat grain in the clean- grain outlet, kg.

BP is the weight of materials other than grains collected in the clean- grain outlet, kg.

The data obtained were statically analyzed using GenStat software edition 3 to determine the effect of cylinder speed, fan speed, concave-cylinder clearance and cylinder type on the above mentioned variables.

### 3.7. Operating principle:

The operation of the wheat crop thresher can be described as follow:

The materials from farmer-harvested wheat grain plants are fed in to the threshing cylinder to flow down freely and directly to the sieve supported by gravity and concave. while shaking, small materials other than healthy wheat grains (including broken grains and half-matured grains) drop down to the trash pan.

Air from the high capacity fan is directed to get rid of lighter trashes, whereas clean wheat grains is forwarded to the clean grain pan supported by gravity and inclination which is controlled manually by jackscrew in front of the machine (Figure 1 and Figure 2).

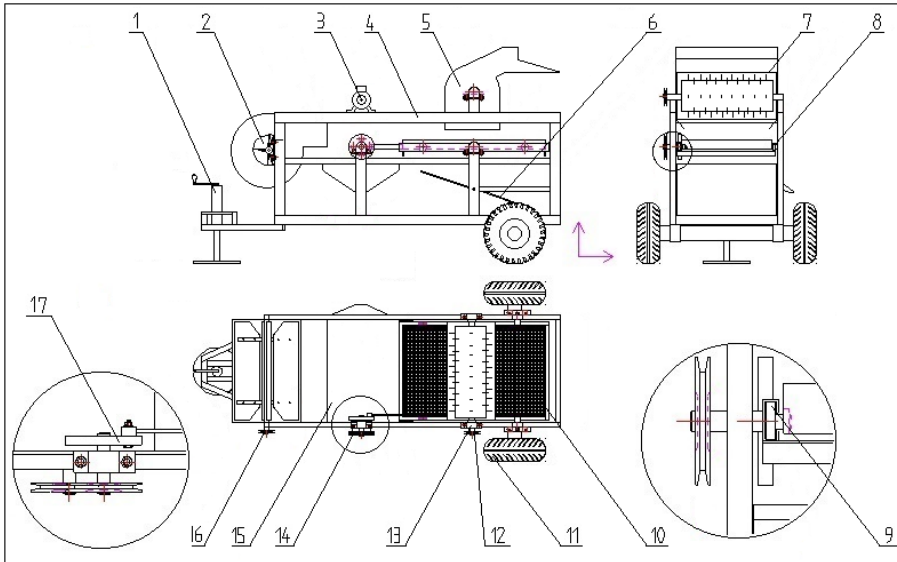

**Figure 1: Schematic diagram of the wheat crop thresher**

1- screw jack, 2- high capacity fan, 3- electric motor, 4- frame, 5- threshing cylinder, 6- trashes pan, 7- threshing drum, 8- shaker, 9- bearing, 10- sieve, 11- driving wheel, 12- drum pulley, 13- bearing housing, 14- shaker pulley, 15- clean grain pan, 16- fan pulley, 17- crank



**Fig. 2: (a) prototype of wheat thresher, (b) threshing drum and concave, (c) clean grain pan**

**Table 3: Effect of different drum speed, fan speed, concave - drum clearance and type of drum on performance parameters**

Treatments	Parameters									
	Threshed grains (g)	Un-threshed grains (g)	Broken grains (g)	Grains blown out with chaff (g)	Grains with stem (g)	Total grains (g)	Threshing efficiency (%)	Separation losses (%)	Cleaning efficiency (%)	Product purity (%)
CS1×FS1×C1×TD1	2337.3 e	742.7 a	116.3 e	233.0 e	174.3 f	2744.7 e	65.9 e	34.1 a	77.3 e	89.2 e
CS1×FS1×C1×TD2	2329.3 f	746.0 a	116.0 e	232.7 f	174.7 e	2736.7 f	65.7 e	34.3 a	77.2 f	89.0 e
CS1×FS1×C2×TD1	2374.3 d	730.3 b	118.3 d	237.0 d	177.7 d	2789.0 d	66.9 d	33.1 b	78.6 d	90.2 d
CS1×FS1×C2×TD2	2372.3 d	733.3 b	118.0 d	236.3 d	177.0 d	2785.7 d	66.9 d	33.1 b	78.5 d	90.2 d
CS1×FS2×C1×TD1	2358.3 e	736.3 b	117.7 d	235.7 e	176.7 e	2770.7 e	66.5 d	33.5 b	78.1 e	89.8 d
CS1×FS2×C1×TD2	2356.3 e	739.0 a	117.3 e	235.7 e	176.3 e	2768.3 e	66.4 d	33.6 b	78.0 e	89.7 d
CS1×FS2×C2×TD1	2392.3 c	720.7 c	119.0 c	238.3 d	178.7 d	2809.3 c	67.4 c	32.6 c	79.2 d	90.7 c
CS1×FS2×C2×TD2	2388.3 d	722.3 c	119.0 c	238.7 c	179.0 c	2806.0 d	67.3 c	32.7 c	79.1 c	90.6 c
CS2×FS1×C1×TD1	2408.3 c	716.3 d	120.0 c	240.3 c	180.0 c	2828.7 c	67.9 c	32.1 c	79.7 c	91.2 c
CS2×FS1×C1×TD2	2404.3 c	717.3 c	119.7 c	240.3 c	180.0 c	2824.7 c	67.8 c	32.2 c	79.6 c	91.1 c
CS2×FS1×C2×TD1	2465.3 a	706.7 e	123.0 a	247.0 a	185.0 a	2897.3 a	69.5 a	30.5 e	81.7 a	92.8 a
CS2×FS1×C2×TD2	2455.3 b	707.3 e	122.7 b	246.0 b	184.7 b	2886.0 b	69.2 a	30.8 e	81.3 a	92.5 a
CS2×FS2×C1×TD1	2445.3 b	711.3 d	121.7 b	244.3 b	183.0 b	2872.7 b	68.9 b	31.1 d	81.0 b	92.2 b
CS2×FS2×C1×TD2	2435.3 b	711.7 d	121.3 b	243.7 b	182.7 b	2861.7 b	68.7 b	31.3 d	80.7 b	92.0 b
CS2×FS2×C2×TD1	2480.7 a	698.3 f	125.0 a	250.7 a	187.3 a	2918.7 a	69.9 a	30.1 e	82.3 a	93.2 a
CS2×FS2×C2×TD2	2472.3 a	700.7 e	125.0 a	252.7 a	188.3 a	2913.3 a	69.7 a	30.3 e	82.1 b	93.0 a
Pr>F	0.0001**	0.0001**	0.0001**	0.0001**	0.0001**	0.0001**	0.0001**	0.0001**	0.0001**	0.0001**

Means within a group followed by same letter are not significantly different at probability P=0.05 by Duncan's multiple range test.



#### 4.1 Effect of different drum speed, fan speed, concave - drum clearance and type of drum on Threshed Grains:

The effect of different drum speed, fan speed, concave - drum clearance and type of drum on Threshed Grains is illustrated in Table 3 the results exposed that the difference between treatments were highly significant ( $P \leq 0.01$ ) having the highest was (2480.7) g in (CS2×FS2×C2×TD1) and the lowest was (2329.3) g in (CS1×FS1×C1×TD2). Generally, the results indicated that threshed grains increased with increasing the cylinder speed, fan speed, concave - drum clearance at rasp-bar type cylinder. Similar results were achieved by Singh and Kumar (1976), Ige (1978), Sharma and Devnani (1980), Desta and Mishra (1990), Hadad (2000), Simonyan and Oni (2001), El-Haddad (2004), Vejasit and Salokhe (2004), Adewumi *et al.*, (2007) and Radwan *et al.*, (2009). Arnold (1964) reported that increasing concave length increased concave separation. The effect of concave length when threshing wheat and barley was studied by Cooper (1978). He reported that a 25% increase of arc from 84° to 105° increased grain separation by 17%. Sarwar and Khan (1987) compared the performance of rasp-bar and wire-loop cylinders for threshing rice crop. They reported that the rasp-bar gave higher percentage of husked grain than wire-loop for all levels of evaluated peripheral speeds. Addo *et al.*, (2004) reported that the rasp-bar drum type provides more surface area for frictional impact.

#### 4.2 Effect of different drum speed, fan speed, concave - drum clearance and type of drum on Un-Threshed Grains:

The results regarding the Un-Threshed Grains are presented in Table 3. The statistical analysis showed a highly significant difference among treatments ( $P \leq 0.01$ ), whereas the lowest was (698.3) g in (CS2×FS2×C2×TD1) and the highest was (746.0) g in (CS1×FS1×C1×TD2). The un-Threshed decreased with an increase in drum speed, fan speed and concave clearance at rasp-bar type cylinder, these results confirm the findings of Singh and Kumar (1976) reported that increasing the cylinder speed decreases un-threshed seed. Dash and Das (1989) stated during development of power operated paddy thresher that, paddy crop with high cylinder peripheral velocity in order to minimize the total un-threshed loss. Abo El-Khair (1991) concluded that the un-threshed seed losses decreased with an increase in drum speed. El-Haddad (2004) designed and manufactured chopping, threshing and winnowing machine suitable for the requirements of some crops residues recirculation. The experimental results showed that the un-threshed grain losses was decreased as the cylinder speed was increased.

#### 4.3 Effect of different drum speed, fan speed, concave - drum clearance and type of drum on Broken Grains:

The results of Broken Grains is exposed in Table 3 which revealed a highly significant difference between treatments ( $P \leq 0.01$ ) the highest level of Broken Grains was (125.0) g in (CS2×FS2×C2×TD1) and the lowest level of Broken Grains was (116.0) g in (CS1×FS1×C1×TD2). Generally, the results indicated that total grain damage increased with increasing the cylinder speed, fan speed, concave - drum clearance at rasp-bar type cylinder. Similar results were achieved by Kolganov (1956), Vas and Harison (1969), Singh and Kumar (1976), Kumar and Goss (1979), Joshi and Singh (1980), Sharma and Devnani (1980), Singh *et al.* (1981), Anwar and Gupta (1990), Alonge and Adegbulugbe (2000), Sudajan *et al.*, (2002), Khazaei *et al.*, (2002), Johnson (2003), Khazaei *et al.*, (2003), El-Haddad (2004), Vejasit and Salokhe (2004), El-Haddad *et al.*, (2006), Askari Asli-Ardeh *et al.*, (2008), Chimchana *et al.*, (2008) and Ponican *et al.*, (2009).

#### 4.4 Effect of different drum speed, fan speed, concave - drum clearance and type of drum on Grains with Chaff:

A highly significant difference between treatments ( $P \leq 0.01$ ) was also revealed in relation to Grains with Chaff as illustrated in Table 3. The highest level of Grains with Chaff was (252.7) g in (CS2×FS2×C2×TD2) and the lowest level of Grains with Chaff was (232.7) g in (CS1×FS1×C1×TD2). The grain with chaff increased with an increase in drum speed, fan speed and concave clearance at wire-loop type cylinder. These results coincide with Vejasit and Salokhe (2004)

studied machine-crop parameters of an axial flow thresher for soybean and reported that threshing drum speed significantly affected the grain losses during soybean threshing.

#### **4.5 Effect of different drum speed, fan speed, concave - drum clearance and type of drum on Grains with Stem:**

The results pertaining to Grains with Stem of as influenced by different drum speed, fan speed, concave - drum clearance and type of drum are shown in Table 3. The results of analysis of variance indicated a highly significant difference between treatments ( $P \leq 0.01$ ) with highest level of Grains with Stem was (188.3) g in (CS2×FS2×C2×TD2) and the lowest level of Grains with Stem was (174.3) g in (CS1×FS1×C1×TD1). The grain with stem increased with an increase in drum speed, fan speed and concave clearance at wire-loop type cylinder. These results coincide with Vejasit and Salokhe (2004) studied machine-crop parameters of an axial flow thresher for soybean and reported that threshing drum speed significantly affected the grain losses during soybean threshing.

#### **4.6 Effect of different drum speed, fan speed, concave - drum clearance and type of drum on Total Grains:**

The results of Total Grains as influenced by different drum speed, fan speed, concave - drum clearance and type of drum are given in Table 3. The results illustrated that the difference between treatments were highly significant ( $P \leq 0.01$ ) having the highest level of Total Grains was (2918.7) g in (CS2×FS2×C2×TD1) and the lowest level of Total Grains was (2736.7) g in (CS1×FS1×C1×TD2). The total grains increased with an increase in drum speed, fan speed and concave clearance at rasp-bar type cylinder.

#### **4.7 Effect of different drum speed, fan speed, concave - drum clearance and type of drum on Threshing Efficiency %:**

The effect of different drum speed, fan speed, concave - drum clearance and type of drum on Threshing Efficiency is illustrated in Table 3. The results illustrated that the difference between treatments were highly significant ( $P \leq 0.01$ ) having the highest value of Threshing Efficiency was recorded (69.9 %) in (CS2×FS2×C2×TD1) and the lowest value of Threshing Efficiency was recorded (65.7 %) in (CS1×FS1×C1×TD2). Generally, the results indicated that efficiency of the machine is directly affected by the threshing speed of the cylinder drum, fan speed, concave - drum clearance at rasp-bar type cylinder. Similar results were achieved by Singh and Kumar (1976), Ige (1978), Sharma and Devnani (1980), Desta and Mishra (1990), Hadad (2000), Simonyan and Oni (2001), El-Haddad (2004), Vejasit and Salokhe (2004), Adewumi *et al.*, (2007) and Radwan *et al.*, (2009).

#### **4.8 Effect of different drum speed, fan speed, concave - drum clearance and type of drum on Separation Losses %:**

Data regarding Separation Losses are shown in Table 3. The results illustrated that the difference between treatments were highly significant ( $P \leq 0.01$ ) having the lowest value of Separation Losses was recorded (30.1 %) in (CS2×FS2×C2×TD1) and the highest value of Separation Losses was recorded (34.3 %) in (CS1×FS1×C1×TD2). The separation losses decreased with an increase in drum speed and with increase in drum concave clearance, fan speed at rasp-bar type cylinder, which is in conformity with Singh and Kumar (1976) reported that increasing the cylinder speed decreases un-threshed seed. Dash and Das (1989) stated during development of power operated paddy thresher that, paddy crop with high cylinder peripheral velocity in order to minimize the total un-threshed loss. Abo El-Khair (1991) concluded that the un-threshed seed losses decreased with an increase in drum speed. El-Haddad (2004) designed and manufactured chopping, threshing and winnowing machine suitable for the requirements of some crops residues recirculation. The experimental results showed that the un-threshed grain losses was decreased as the cylinder speed was increased. Arnold (1964) reported that increasing concave length increased concave separation. The effect of concave length when threshing wheat and barley was studied by Cooper (1978). He reported that a 25% increase of arc from 84° to 105° increased grain separation by 17%.

#### 4.9 Effect of different drum speed, fan speed, concave - drum clearance and type of drum on Cleaning Efficiency %:

The results pertaining to Cleaning Efficiency of as influenced by different drum speed, fan speed, concave - drum clearance and type of drum are shown in Table 3. The results of analysis of variance indicated a highly significant difference between treatments ( $P \leq 0.01$ ) with highest level of Grains with Stem was (82.3 %) in (CS2×FS2×C2×TD1) and the lowest level of Cleaning Efficiency was (77.2 %) in (CS1×FS1×C1×TD2). The cleaning efficiency increased with an increase in drum speed, fans peed, concave clearance at rasp-bar type cylinder, which is in conformity with Joshi and Singh (1980) developed Pantnagar IRRI multi-crop thresher. They observed that cleaning efficiency increased with an increase in the cylinder speed of the thresher.

#### 4.10 Effect of different drum speed, fan speed, concave - drum clearance and type of drum on Product Purity:

The effect of different drum speed, fan speed, concave - drum clearance and type of drum on Product Purity is illustrated in Table 3. The results illustrated that the difference between treatments were highly significant ( $P \leq 0.01$ ) having the highest value of Product Purity was recorded (89 %) in (CS2×FS2×C2×TD1) and the lowest value of Product Purity was recorded (93.2 %) in (CS1×FS1×C1×TD2). The product purity increased with an increase in drum speed, fans peed, concave clearance at rasp-bar type cylinder.

### 5. Conclusions:

The following conclusions can be drawn from this research:

- Drum speed, fan speed, concave clearance and drum type play important role in affecting threshed grain quality of wheat. Among all these machine and crop parameters, drum speed is most important.
- Fan speed is very critical factor affecting thresher performance with respect to wheat threshing.
- The combination of 900 rpm: drum speed, 20 mm: concave clearance and 1390 rpm: fan speed found optimum to yield high quality grain of wheat and efficient threshing.
- Results obtained showed a high efficiency of threshing at rasp-bar type cylinder.
- The threshing efficiency, separation losses, cleaning efficiency and product purity which were 69.9 %, 30.1 %, 82.3 % and 93.2 % respectively.

### Acknowledgements:

The researcher would like to thank the administration of Alshamaliya for Agricultural Services Company for providing the research funding and manufacturing facilities.

### References:

- Abo EL-kheir, M. M. (1991). Effect of some factor on threshing performance of soybean, *Misr J .Ag. Eng.*, 8 (3):172-181.
- Addo, A., A. Bart-Plange, R.A. Asuboah and K. Dzisi (2004). Effect of different threshing cylinders on soybean quality. *J. Sci. Technol.*, 24: 121-125.
- Adewumi K, A. Olayanju and A. Adewuyi (2007). Support for small rice threshers in Nigeria, *Journal of the University of Agriculture, Abeokuta, Nigeria* 23(1): 22-24.
- Agidi, G., Ibrahim, M. G. and Matthew, S. A. (2013). Design, fabrication and testing of a millet thresher. *Net Journal of Agricultural Science*. Vol. 1(4), pp. 100-106.
- Alizadeh, M. R. and Bagheri, I. (2009). Field Performance Evaluation Of Different Rice Threshing Methods . *International Journal Of Natural And Engineering Sciences* , 3 (3), 155-159.
- Alonge, A. F. and Adegbulugbe, T. A. (2000). Performance Evaluation of a Locally-Developed Grain Thresher-II. *Agricultural Mechanization in Asia, Africa and Latin America, Japan*. Volume 31, No 2, Spring, page 52 – 54.

- Anwar, M.T. and G. P. Gupta. (1990). Performance evaluation of chick pea thresher in Pakistan AMA 21 (5) : 23-28Ajayi, O. A.
- Arnold, R. E. (1964). Experiments with rasp bar threshing drums. I. Some factors affecting performance. J. Agric. Eng. Res. 9(2): 99-131.
- Askari Asli-Ardeh, E. and Abbaspour- Gilandeh, Y. (2008). Investigation of the effective factors on threshing loss, damaged grains percent and material other than grain to grain ratio on an auto head feed threshing unit. American Journal of Agricultural and Biological Sciences. 3(4), 699-705.
- Asli-Ardeh, E. A., Abbaspour-Gilandeh, Y. and Abbasi, S. (2009). Study Of Performance Parameters Of Threshing Unit In A Single Plant Thresher.
- Behera, B. K, Dash S. K, and Das D. K. (1990). Development and testing of a power operated wheat thresher. Agricultural Mechanization in Asia, Africa and Latin America (AMA), 21(4): 15-21.
- Chimchana, D., Salokhe, V.M. and Soni, P. (2008). Development of an unequal speed co-axial split-rotor thresher for rice. the CIGR Ejournal. Manuscript PM08017, 1-11.
- Cooper, G. F. (1978). Cylinder/concave performance from laboratory tests. II. In Grain and forage harvesting. Proc. of First International Grain and Forage Conf., Iowa State University, Ames, Iowa, 1977. ASAE, St. Joseph, Mich.
- Dash, S. K., and D. K. Das. (1989). Development of a power operated paddy thresher. Journal of AMA, 20(3) : 37-39.
- Desta K, Mishra T N. (1990). Development and performance evaluation of a Sorghum thresher. Agricultural Mechanization in Asia, Africa and Latin America (AMA), 21(3): 33 – 37
- Edison, A.R. and W.L. Brogan (1972). Size measurement statistics of kernels of six grains. Paper 72-841. American Society of Agricultural Engineers, St. Joseph, Michigan 49085.
- El Faki, M. H. (2000). Agricultural extension and agricultural research linkages in the Sudan with special reference to Gezira scheme. PhD thesis. Gezira University, Wad Medani.
- El-Haddad, W.Z. (2004). Manufacture and evaluation chopping, threshing and winnowing machine suitable for the requirements of some crops residues recirculation. Ph. D. Thesis, Agric. Mech. Dept., Fac. Agric., Kafr El-Sheik University.
- El-Haddad, W.Z., M.I. Shoughy, A.L. El-Kewey and N.H .Abo El- Hana (2006). Development of local made machine model El-Haddad-wz to suit threshing and separation faba bean crop. Misr J. Ag. Eng., 23 (4): 943-962.
- Fageeri, E. A. (2005). Comparative marginal wheat production economics of small and large schemes in the Northern State, Sudan (unpublished). Dongola Research Station P.O. Box 35- Dongola.
- Ghaly, A. E. (1985). A stationary threshing machine: Design construction and performance evaluation. Agricultural Mechanization in Asia, Africa and Latin America (AMA), 16(3): 19-30.
- Hadad, W.Z. (2000). A simplified design and performance study of threshing and winnowing machine suitable for small holdings. M. Sc. Thesis. Agric. Mech., Fac. Of Agric., Kafr El-Sheikh, Tanta Univ.
- Igbeka, J. C. 1984. An appropriate technology cereal cleaner. AMA, 15(2), 67-71.
- Ige, M. T. (1978). Threshing and separation performance of a locally built cowpea thresher. J. Agril. Engg. Res., 23(1): 45-51.
- Johnson, R. (2003). " Setting threshers for harvesting best quality seed and field corn" Director, cooperative Extension service, Iowa state univ. of science and Technology, Ames. Iowa, file: Engin.2-2. "PDCA12-70 data sheet," Opto Speed SA, Mezzovico, Switzerland.
- Joshi H. C. and K. N. Singh. (1980). Development of Pantnagar IRRI multi-crop thresher. Journal of

AMA : pp 53-63.

- Joshi, H. C. (1981). Design and selection of thresher parameter and components. *Agricultural Mechanization in Asia, Africa and Latin America (AMA)*, 21(3): 29-32.
- Kabesh, M.O., M.F. El-kramany, G.A. Sary, H.M. El-Naggar, and H.B. Gehan Sh (2009). Effects of sowing methods and some bio-organic fertilization treatments on yield and yield components of wheat. *Res. J. Agric. Biol. Sci.* 5; 97-102.
- Khazaei, J., Behrouzi lar, M., Rajabipour, A. and Mohtasebi, S. (2003). Effect of Impact Velocity, Moisture Content and Pod Size on Percentage of Damaged Grains and Threshed Pods in a Finger Type Combine Thresher. *Iran. J. Agric. Sci.*, 34: 825-836.
- Khazaei, J., M. Behrooz Lar, A. Rajabi Pour, S. Mohtasebi (2002). Mechanical Strength of Chick Pea Grain and Pod Under Impact Loading. Written for presentation at the Aic 2002 Meeting, CSAE / SCGR Program Saskatoon, Saskatchewan, July 14 -17.
- Kolganov, K.G (1956). Mechanical damage to grain during threshing. *J.Agril. Sci.*, 27; 179.
- Kumar, R. and J.R. Goss (1979). Analysis and modeling of alfalfa seed harvest losses. *Trans. ASAE*, 22: 237-42.
- MoFEP (2012). Economic indicators in the Northern State. Report of Ministry of finance and Economic Planning 2012. Northern State, Sudan.
- Mohsenin, N.N. (1970). *Physical Properties of Plant and Animal Materials*. Gordon and Breach Science Publishers, New York. 734 p.
- Ponican, J., Angelovic, M., Jech, J., Zitnak, M., Galambosova, J. and Findura, P. (2009). The Effect of the Design Concept of Combine Harvester Threshing Mechanism on the Maize Crop Threshing Quality. *Savremena poljoprivredna tehnika*, 35(4): 268-274.
- Radwan, G.G., Salim. R.G., & Al-Ashry, A.S. (2009). Development and test attachments to the tangential flow thresher to suit caraway crop threshing. *Misir J. Ag. Eng.*, 26(3): 1068-1080.
- Saad, A.S (2010). The Influence of *Triticum Aestivum* Seeding Rates and Sowing Patterns on the Vegetative Characteristics in Shambat Soil under Irrigation. *Research J. of Agric. Bio. Sci.* 6(2); 93-102.
- Sarwar, J.G. and Khan, A.U. (1987). Comparative performance of rasp-bar and wire-loop cylinder for threshing rice crop. *Agricultural Mechanization in Asia, Africa and Latin America*. 18(2), 37-42.
- Sharma, K. D. and R. S. Devnani (1980). Threshing studies on soybean and cowpea. *AMA*, 33(2): 65-68. *Trans. ASAE*. Paper No.0001-2351.
- Simonyan K. J. and K. C. Oni (2001). Performance evaluation of a motorized locust bean decorticator. *Journal of Agricultural Technology* 9(1): 55 - 65.
- Singh, B. and Kumar, A. (1976). Effect of cylinder type on threshing effectiveness and damage of wheat. *J. Agril. Engg.*, 13(3): 124-129.
- Singh, K. N. and B. Singh (1981). Effect of crop and machine parameters on threshing effectiveness and seed quality of soybean, *Journal of Agricultural Engineers Research (JAER)*, 17: 23-28.
- Srivastava, A.K., Mahoney, W.T., West, N.L. (1990). The effect of crop properties on combine performance. *Trans. of ASAE*. 33, 63-72.
- Sudajan, S., Salokhea, V. M. and Triratanasrichai, K. (2002). Effect of Type of Drum, Drum Speed and Feed Rate on Sunflower Threshing. *Biosys. Eng.*, 83(4): 413-421.
- Vas and Harison (1969). The effect of selected mechanical threshing parameters on kernel damage and thresh ability of wheat. *Canadian agricultural Engineering* 11(2): pp 83-91.
- Vejasit, A. and Salokhe, V. M. (2004). Studies on Machine-Crop Parameters of an Axial Flow Thresher for Threshing Soybean. *Agric. Eng. Int.*, PAPER 04 004. PP.12.